

BRONZE CLOSE COUPLED RUBBER IMPELLER PUMP

PIPE SIZE 3/8"



FEATURES

- Compact Size
- Bronze Construction - Corrosion Resistance
- Buna Lip Seal
- Large Vent Openings Separate Pump & Motor
- Stainless Steel Motor Shaft
- Motor Shaft Slinger Protects Motor Bearings
- Rubber Motor Grommets for Noise Isolation
- Impeller and Cam Easily Replaced
- Garden Hose Threads (External) & Pipe Threads (Internal) for Port Connections
- Available with 12, 24 and 32 volt D.C. Motor Drive
- Neoprene Impeller Standard (optional Buna Impeller - 04)
- For Close Coupled AC Motor units, see Models 211D and 211M
- Marine uses include Bilge, Washdown, Baitwell and General Transfer

MOUNTING

Horizontal motor mountings - including sidewall mountings - are recommended. The pump can be mounted in any of 4 positions 90° apart. Two screws attach pump to motor.

PUMP & DC MOTOR UNIT PERFORMANCE

Water 70°F Neoprene Impeller 6617

Motor	Volts	HP	Head (Feet)	8.7	10	15	20	25	30
	FL. Amps	Nom. Speed	Pressure (PSI)	3.8	4.3	6.5	8.7	10.8	13.0
A88	12 V DC	1/10	Flow (GPM)	7.1	6.8	6.3	5.9	5.1	4.1
			Speed (RPM)	2290	2280	2200	2190	2130	2080
8029	14 Amps	2300	Current (Amps)	11.5	12.1	12.3	12.7	13.0	14.0

A89	24 V DC	1/10	Flow (GPM)	7.8	7.6	7.0	6.6	6.0	
			Speed (RPM)	2490	2490	2460	2440	2410	
8030	6 Amps	2300	Current (Amps)	5.3	5.1	5.4	5.8	6.0	

A90	32 V DC	1/10	Flow (GPM)	7.9	7.8	7.2	6.7	6.1	5.2
			Speed (RPM)	2530	2520	2480	2470	2450	2420
8031	5 Amps	2300	Current (Amps)	4.0	4.1	4.3	4.6	4.8	5.1

Notes:

- 1) Maximum recommended continuous duty operating point

DRIVE AND ROTATION

Motor drive is clockwise facing pump end. Liquid flow direction is right to left facing pump end. Correct D.C. voltage must be supplied to motor - 12, 24 or 32 volts as specified on motor name plate.

DO NOT RUN DRY

Rubber impellers generate high rubbing friction unless lubricated by the liquid pumped. Lack of liquid will cause impeller to burn up.

LIQUID AND TEMPERATURE

Liquids compatible with neoprene can be pumped including fresh and salt water solutions and mild chemicals. Do not pump severe solvents or acids. When possible, flush pump with fresh water after each usage. Buna N impellers can handle oil contaminated water at reduced impeller service life.

Extremes of cold and heat will affect impeller life. Limits of 40° to 140° F should be observed. Do not allow liquid in pump to freeze. Drain pump by loosening cover screws. Use methyl alcohol based anti-freeze compounds such as Zerex, Shell Zone, Pyro Permanent, Permagard, Dowgard.

SUCTION LIFT

Suction lift of 3 ft. is possible when impeller is wet. Suction lines must be air tight in order for pump to self prime. A foot valve at the beginning of suction line is recommended.

IMPELLER REPLACEMENT

The impeller must be replaced if it is worn out or has been damaged by debris or by running the pump dry. Symptoms of a defective impeller are low pumping pressure and low flow.

To replace the impeller remove screws and cover. Pull out the impeller with nose pliers or two screwdrivers. Be careful not to dent the pumping chamber with these tools. When inserting new impeller, line up the flat in impeller with the flat in the shaft. Use oil on shaft and avoid forcing the impeller onto the shaft.

The impeller should also be removed for storage periods to prevent the blades from taking a permanent set.

SEAL REPLACEMENT

If water drips from the vent opening or from the area where the shaft exits the pump, the seal is defective and must be replaced. While the slinger provides a first line of defense, prolonged running of the pump with a leaky seal can destroy the motor's ball bearings resulting in catastrophic pump failure.

For seal replacement, the pump must be removed from the motor and disassembled in order to gain access to the seal area. Lip seals must be pushed out of their press-fitted position and new seals pressed into place, using a sealant on the outside of the lip seal housing.

Refer to exploded view drawings for seal location and part numbers for ordering purposes.

BRONZE CLOSE COUPLED RUBBER IMPELLER PUMP

EXPLODE VIEW AND PARTS LIST

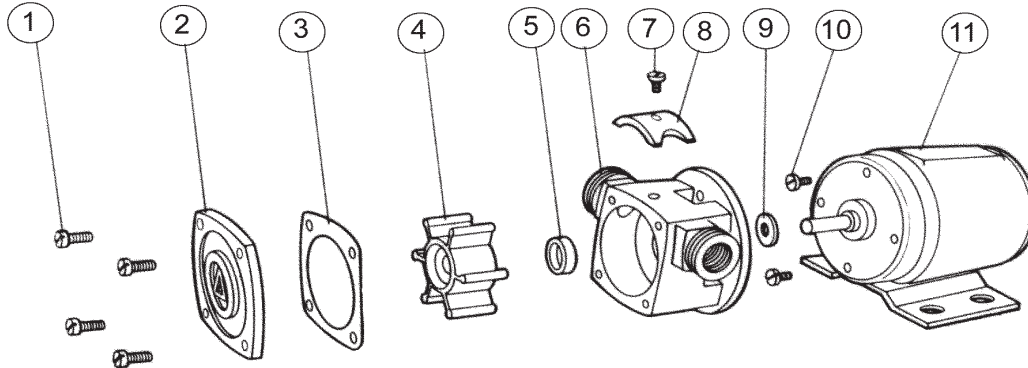

Pump #	Config	1a	1b	2	3	4	5	6	7	8	9	10	11	12*	13*	Repair Kit
		Screw	Screw	Cover	Gasket	Impeller	Lip Seal	Body	Cam Screw	Cam	Slinger	Screw	Motor	Lock Washer	Grommet	
201D	Neoprene	2 Req'd	2 Req'd	1 Req'd	1 Req'd	1 Req'd	1 Req'd	1 Req'd	1 Req'd	1 Req'd	1 Req'd	2 Req'd	1 Req'd	2 Req'd	4 Req'd	10703
201D-04	Buna	2 Req'd	2 Req'd	1 Req'd	1 Req'd	1 Req'd	1 Req'd	1 Req'd	1 Req'd	1 Req'd	1 Req'd	2 Req'd	1 Req'd	2 Req'd	4 Req'd	11666

Motor #	Config	
A88	1/10 HP, 2300 RPM, 12 VDC, TEFC	8029
A89	1/10 HP, 2300 RPM, 24 VDC, TEFC	8030
A90	1/10 HP, 2300 RPM, 32 VDC, TEFC	8031

Repair Kit includes items 3,4,5

* Items not shown

PUMP & MOTOR OPTIONS

Note: These are the most frequently used pump and motor combinations. If you have other needs, our sales reps can recommend a pump and motor for your application.

DIMENSIONS

