

BRONZE CLOSE COUPLED RUBBER IMPELLER PUMP

SEWAGE - MACERATOR - D.C. MOTOR DRIVE

**PIPE SIZE INLET: 2" SLIP-ON HOSE
1 1/2" PIPE THREAD**

**OUTLET: 3/4" GARDEN HOSE AND
3/8" PIPE THREAD**



FEATURES

- All Bronze Construction
- Large Vent Openings Separate Pump and Motor
- Stainless Steel Motor Shaft
- Motor Shaft Slinger Protects Motor Bearings
- Rubber Motor Grommets for Noise Isolation
- Macerator Wheel and Impeller Easily Replaced
- Removable Base

PUMP INLET

2" slip-on hose section with 1 1/2" NPT standard pipe male thread. All suction connections must be air tight to achieve lift.

PUMP OUTLET

3/4" external garden hose thread with 3/8" NPT standard pipe thread internal.

MACERATOR

Will handle sewage, waste, toilet paper, cigarettes, cigars and all maceratable solids of approximately 1 inch size.

Will not handle fruit pits, hard plastic utensils, prophylactics, cloth or fabric sanitary napkins.

MOTOR

12 volt D.C. high torque, 18 amps. Intermittent duty cycle. Do not run pump dry. 24V and 32V also available.

SUCTION AND DISCHARGE

Self priming up to 4 ft. Up to 20 ft. uphill discharge or up to 50 ft. away. (Use large diameter garden hose - 3/4" - for best results.) A 30 gallon holding tank can be emptied in less than 4 minutes.

CAPACITY Gallons of Water Per Minute 60°F

P.S.I.	0	2	4	6	8	10	12
Flow G.P.M.	9	8	7	6	4 1/2	3	1

LIQUIDS AND TEMPERATURE

Liquids compatible with neoprene can be pumped including fresh and salt water solutions and mild chemicals. Do not pump severe solvents or acids. When possible, flush pump with fresh water after each usage. Buna N impellers can handle oil contaminated water and kerosene at reduced impeller service life.

Extremes of cold and heat will affect impeller life. Limits of 40° to 140° F should be observed. Do not allow liquid in pump to freeze. Drain pump by loosening cover screws. Use methyl alcohol based anti-freeze compounds such as Zerex, Shell Zone, Pyro Permanent, Permagard, Dowgard.

SUCTION LIFT

Suction lift of 15 feet is possible when impeller is wet. Suction lines must be air tight in order for pump to self prime. A foot valve at beginning of suction line is recommended.

IMPELLER REPLACEMENT

The impeller must be replaced if it is worn out or has been damaged by debris or by running the pump dry. Symptoms of a defective impeller are low pumping pressure and low flow.

To replace the impeller, remove screws and cover. Remove macerator wheel, plate and gaskets. Pull out the impeller with nose pliers or two screwdrivers. Be careful not to dent the pumping chamber with these tools. When inserting new impeller, line up flat on impeller with flat on the shaft. Use oil on shaft and avoid forcing the impeller onto the shaft.

The impeller should also be removed for storage periods to prevent the blades from taking a permanent set.

SEAL REPLACEMENT

If water drips from the weep hole or from the area where the shaft exits the pump, the seal is defective and must be replaced. While the slinger provides a first line of defense, prolonged running of the pump with a leaky seal can destroy the ball bearings resulting in catastrophic pump failure and engine shut-down.

For seal replacement, the pump must be removed from the engine and disassembled in order to gain access to the seal area. Where mechanical seals are used, both components (stationary and rotating member) must be replaced at the same time. Lip seals must be pushed out of their press-fitted position and new seals pressed into place, using a sealant on the outside of the lip seal housing.

Refer to exploded view drawings for seal location and part numbers for ordering purposes.

DUCTILE IRON CLOSE COUPLED ROTARY GEAR PUMPS

EXPLODED VIEW AND PARTS LIST

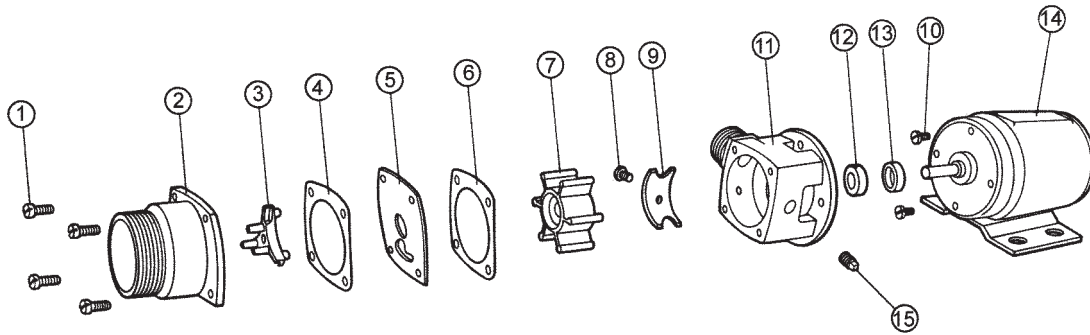

Pump No.	1	2	3	4 ¹	5	6 ¹	7 ¹	8	9	10	11	12 ¹	13	14 ²	15	16 ³	17 ³	Repair Kit ¹	
	Screw	Cover	Wheel	Gasket	Plate	Gasket	Impeller	Cam Screw	Cam	Screw	Body	Lip Seal	Slinger	Motor	Plug	Grommet	Washer		
	4 Req'd	1 Req'd	1 Req'd	1 Req'd	1 Req'd	1 Req'd	1 Req'd	1 Req'd	1 Req'd	2 Req'd	1 Req'd	1 Req'd	1 Req'd	1 Req'd	1 Req'd	4 Req'd	4 Req'd		
209M	6074	7088	7097	7020	7089	6654	6617	7300-41	6592	7424	7185	6647	6651	---	6052	---	5656	10829	

¹ Repair Kit contains items 4, 6, 7 & 12.

² See motors below.

³ Parts not shown.

PUMP & MOTOR OPTIONS

Note: These are the most frequently used pump and motor combinations. If you have other needs, our sales reps can recommend a pump and motor for your application.

Motor	Part #	Specs
A93	8109	1/10 HP, 2600 RPM, 24 v, Single, TEFC
A92	8108	1/10 HP, 2600 RPM, 12 v, Single, TEFC
A94	8110	1/10 HP, 2600 RPM, 32 v, Single, TEFC

DIMENSIONS

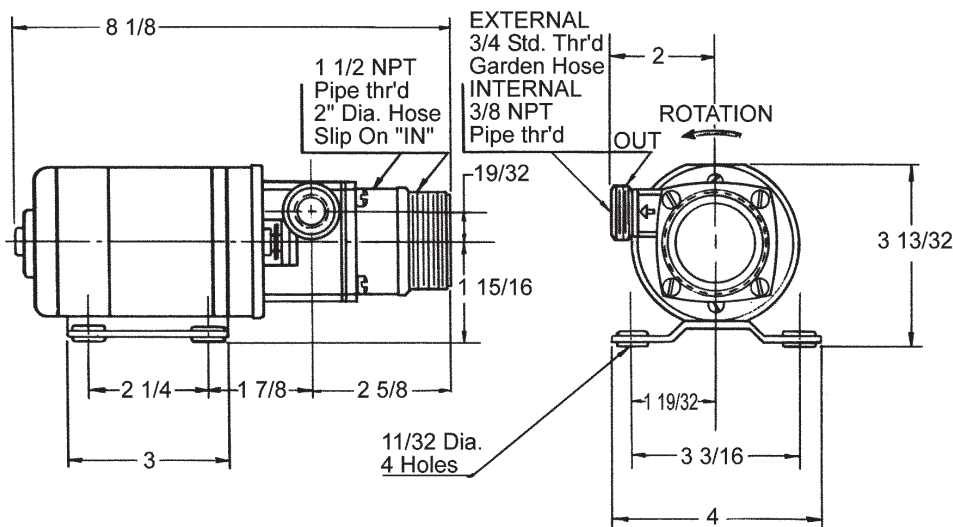

USES

- Utility
- Trailers
- Boats
- Railroads
- Buses
- Motor Homes
- Emergency Campers
- Mobil Homes
- Cottages
- Camp Sites
- Aircraft
- Marine Transportation
- Recreational Vehicles
- Land & Water Cruisers
- Commercial & Pleasurecraft