

BRONZE MACERATOR RUBBER IMPELLER PUMP

PIPE SIZE: IN 1 1/2"
OUT 3/8" AND 3/4" GARDEN HOSE



214M-F35 SHOWN

FEATURES

- All bronze construction - sturdy, corrosion resistant
- Large vent openings separate pump and motor
- Stainless steel motor shaft
- Motor shaft slinger protects motor bearings
- Three conductor motor cord
- Neoprene Impeller compound eliminates seizing and motor overload - Optional Buna Impeller (-05)
- Macerator wheel and impeller easily replaced
- High torque capacitor start 1/3 HP TEFC motor
- For sewage transfer from toilets to holding tanks
- For pump-out and disposal from holding tanks

IMPORTANT - DO NOT RUN DRY

Flexible impellers generate high rubbing friction unless lubricated by liquid being pumped. Lack of liquid will cause impellers to burn up. It is important to avoid dry start-ups. Usually sufficient liquid for a "wet" start is trapped in pump piping system during normal usage. If not, inject water or lubricating oil thru inlet or outlet ports or thru pipe plug openings on pump castings. (Caution - do not remove flush pan=head screw holding pump body cam in position - see exploded view). It is most important to insure a "wet" start when a pump is being used for the first time in a new installation or after a prolonged storage period when all liquid has evaporated. Any plugs removed from pump body or cover must be retightened prior to start up.

MACERATOR WILL

Handle sewage, waste, toilet paper, cigarettes, cigars, and all maceratable solids of approximately 1 inch size.

MACERATOR WILL NOT

Handle fruit pits, hard plastic utensils, prophylactics, cloth or sanitary napkins.

PUMP INLET - SUCTION

Pump inlet is 1 1/2" NPT standard pipe thread. All suction connections must be air tight and as short as possi-

CAPACITY Water at 60°F

Ft. HD.	0	10	20	30	40	50	60	70
PSI	0	4.3	8.7	13.0	17.3	21.7	26.0	30.0
G.P.M.	12 1/2	12 1/4	11 1/2	11	10	9	8	6 1/2

ble to achieve lift. A suction lift of up to 4 feet is possible under ideal conditions. Because the suction line for sewage handling is of large size (1 1/2" pipe) a large volume of air must be evacuated to create vacuum and suction lift. This is why a "wet" start is essential to prevent overheating and burning of the impeller during the air evacuation and suction period.

PUMP OUTLET - DISCHARGE

Pump outlet is 3/4" garden hose thread external and 3/8" NPT standard pipe thread internal. Use large inside diameter garden hose 3/4" for best results. Avoid restricting connectors and fittings and hoses with same. Keep discharge system as large and as short as possible.

LIQUIDS AND TEMPERATURE

Liquids compatible with neoprene can be pumped including fresh and salt water solutions and mild chemicals. Do not pump severe solvents or acids. When possible, flush pump with fresh water after each usage. Buna N impellers can handle oil contaminated water and kerosene at reduced impeller service life.

Extremes of cold and heat will affect impeller life. Limits of 40° to 140° should be observed. Do not allow liquid in pump to freeze. Drain pump by loosening cover screws. Use methyl alcohol based anti-freeze compounds such as Zerex, Shell Zone, Pyro Permanent, Permagard, or Dowgard.

IMPELLER REPLACEMENT

The impeller must be replaced if it is worn out or has been damaged by debris or by running the pump dry. Symptoms of a defective impeller are low pumping pressure and low flow.

To replace the impeller, remove screws and cover. Remove macerator wheel, plate and gaskets. Pull out the impeller with nose pliers or two screwdrivers. Be careful not to dent the pumping chamber with these tools. When inserting new impeller, line up flat on impeller with flat on the shaft. Use oil on shaft and avoid forcing the impeller onto the shaft.

The impeller should also be removed for storage periods to prevent the blades from taking a permanent set.

SEAL REPLACEMENT

If water drips from the weep hole or from the area where the shaft exits the pump, the seal is defective and must be replaced. While the Teflon(R)* barrier seal provides a first line of defense, prolonged running of the pump with a leaky seal can destroy the ball bearings resulting in catastrophic pump failure and motor shut-down.

For seal replacement, the pump must be removed from the motor and disassembled in order to gain access to the seal area. Lip seals must be pushed out of their press-fitted position and new seals pressed into place using a sealant on the outside of the lip seal housing.

Refer to exploded view drawings for seal location and part numbers for ordering purposes.

BRONZE MACERATOR RUBBER IMPELLER PUMP

EXPLODED VIEW AND PARTS LIST

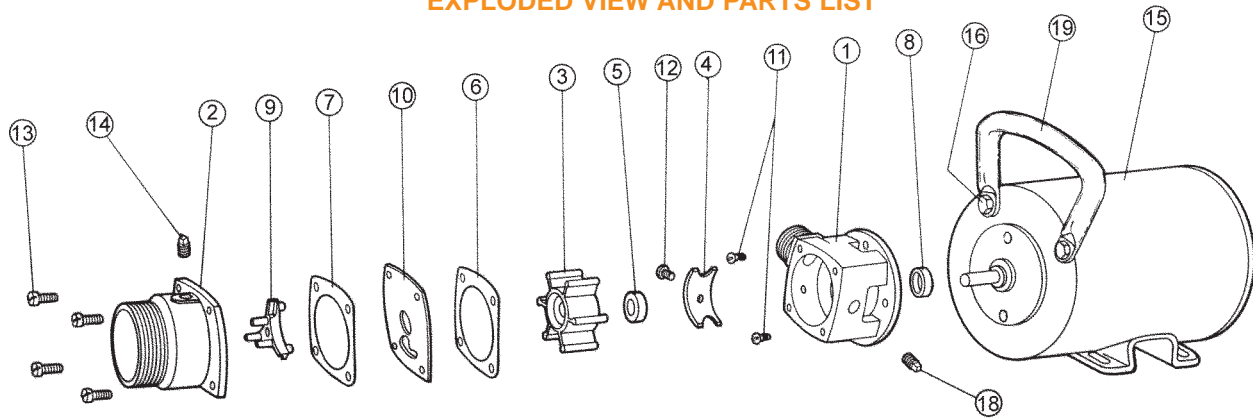

Pump No.	1	2	3 ¹	4	5 ¹	6 ¹	7 ¹	8	9	10	11	12
	Body	Cover	Impeller	Cam	Lip Seal	Gasket	Gasket	Slinger	Wheel	Plate	Screw	Screw
	1 Reqd	1 Reqd	1 Reqd	1 Reqd	1 Reqd	1 Reqd	1 Reqd	1 Reqd	1 Reqd	1 Reqd	2 Reqd	1 Reqd
214M	7454	7446	6593	6592	5007	7547	7020	6757	7442	7089	2371	7300-41
214M-F35	7454	7446	6593	6592	5007	7547	7020	6757	7442	7089	2371	7300-41
214M-05F35	7454	7446	8514	6592	5007	7547	7020	6757	7442	7089	2371	7300-41

¹ Repair Kit contains items 3, 5, 6 & 7.

² Items not shown.

13	14	15	16	17 ²	18	19	20 ²	21 ²	22 ²	23 ²	Repair Kit ¹
Screw	Plug	Motor	Screw	Cord	Plug	Handle	Washer	Terminal Spade	Wire Nut Orange	Wire Nut Yellow	
4 Reqd	1 Reqd	1 Reqd	2 Reqd	1 Reqd	1 Reqd	1 Reqd	2 Reqd	1 Reqd	2 Reqd	1 Reqd	
6074	7043	---	---	---	6052	---	5656	---	---	---	10938
6074	7043	7429	5411	6761	6052	9897	5656	7297	9850	9857	10938
6074	7043	7429	5411	6761	6052	9897	5656	7297	9850	9857	

DIMENSIONS

