

BRONZE PEDESTAL CENTRIFUGAL PUMPS

PIPE SIZE: INLET 1 1/4", OUTLET 1"

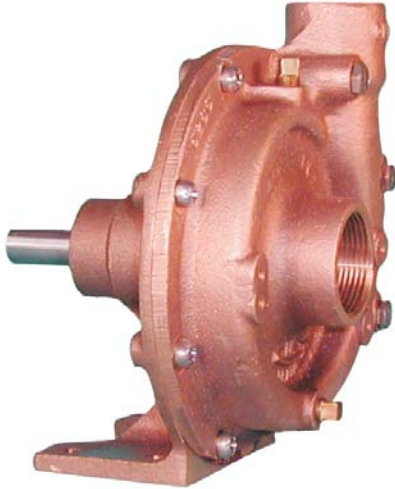

FEATURES

- Rugged Bronze Construction
- Quiet Operation
- O-Ring Housing seal eliminates gasket problems
- Mechanical Seal - Carbon/Ceramic
 - Buna - standard
 - Viton (S10) or Teflon (S11) - options
- Designed for Pulley Drive
- Heavy Duty Integral Steel Shaft and Ball Bearings
- Handles Contaminated Liquids
- No bearing lubrication required
- For Close Coupled Style, see Model 700

USES

Silent, efficient, centrifugal pumping is ideal for convenient equipment location in offices, laboratories, public areas, and living quarters. Long trouble-free service life has made centrifugal pumps acceptable for industrial uses or wherever clean or contaminated liquid compatible with bronze is to be transferred or handled.

The 70P centrifugal pump has an external ball bearing isolated from the liquid being pumped. The ball bearing is greased and sealed for life, requiring no maintenance.

CHARACTERISTICS

Oberdorfer centrifugal pumps have a single rotating metal impeller. Liquid enters at the center and is thrown outward radially by centrifugal force. The impeller is not in contact with other pump parts resulting in quiet, efficient, pumping action. The flow produced is not positive which permits the discharge line to be shut off completely without danger of overloading motors or bursting lines. Consequently a relief valve is not required.

The liquid flow varies directly as the pump speed--the higher the speed the greater the flow. Horsepower required varies directly as flow and pressure. Maximum horsepower is required with a wide open discharge line. This is the point of

Capacity - Water at 70° F

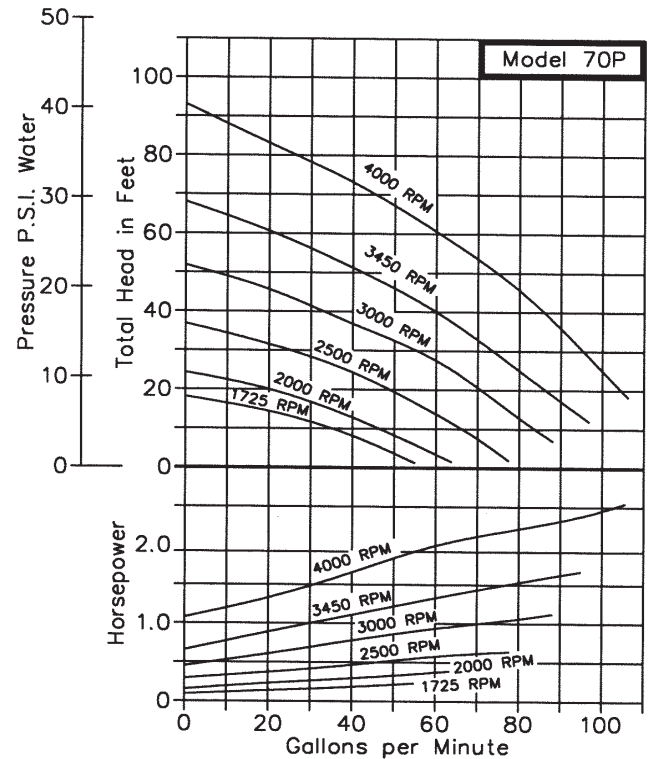

maximum flow. With a throttled discharge, the flow decreases at a greater rate than the pressure increases thereby requiring less horsepower at the higher pressures. This is known as an "unloading" feature of the pump.

This centrifugal pump is not self priming. Normally these pumps must be installed below the liquid level so that the liquid flows to the pump by gravity. However, if a foot valve is used at the beginning of the suction line and all air is bled from the suction line and pumping by careful manual priming, these pumps will lift liquid on the suction side up to 15 ft. Such a system is only as positive as the ability of the foot valve to seal and keep the suction line and pump full of liquid. If the foot valve should leak, the pump will not prime.

The pedestal centrifugal pumps can be direct driven by electric motors at either 3450 R.P.M. or 1725 R.P.M. Performance for both speeds are shown in the curves above. The 70P pedestal centrifugal pump can be pulley driven at any desired intermediate speed.

Because centrifugal pumps are more efficient at higher shaft speeds, pumping of viscous or thick liquids is difficult. It is possible to lose as much as 40% pump performance when attempting to pump liquids of viscosity equal to S.A.E. 30 oil at room temperature. S.A.E. 30 oil at room temperature has a viscosity of 2000 Saybolt Seconds Universal. More viscous liquids are not recommended for centrifugal pumps.

Heavy liquids can be pumped; however, they demand more horsepower in direct ratio to the weight of water. For example, car-

BRONZE PEDESTAL CENTRIFUGAL PUMPS

EXPLODED VIEW AND PARTS LIST

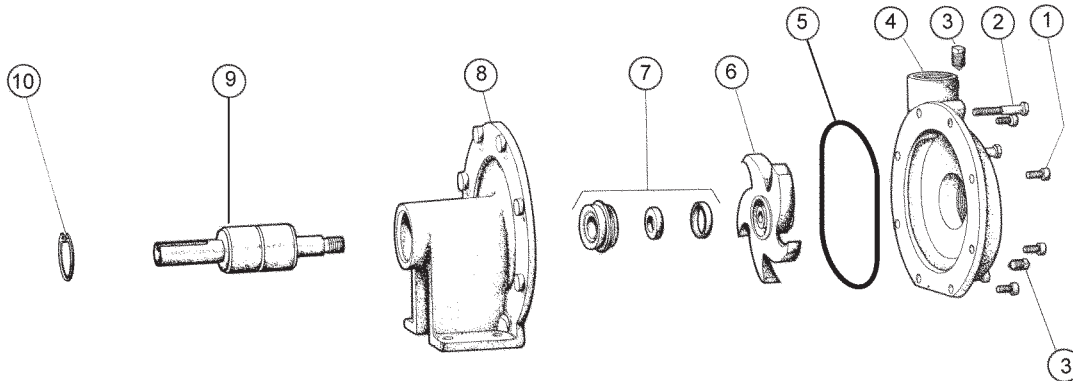

Pump No.		1	2	3	4	5 ¹	6 ¹	7 ¹	8	9 ¹	10	11	Repair Kit
		Screw	Screw	Plug	Body	O-Ring	Impeller	Seal Assembly	Pedestal Cover	Shaft & Bearing	Ret. Ring	Set Screw	
		5 Req'd	3 Req'd	2 Req'd	1 Req'd	1 Req'd	1 Req'd	1 Req'd	1 Req'd	1 Req'd	1 Req'd	1 Req'd	
70P	Buna Mechanical	9783-04	9783-14	5395	5266	9797-157	5267	32154	5272	5348	5741	---	10693
70PS-10	Viton Mechanical	9783-04	9783-14	5395	5266	9797-157	6179	32210	5272	5348	5741	---	11161
70PS-11	Teflon Mechanical	9783-04	9783-14	5395	5266	9355-157	6179	32211	6358	5348	5741	---	11366
70P-35	Buna, Keyed Shaft, 3 Phase Impeller	9783-04	9783-14	5395	5266	9797-157	6521	32154	5272	8114	5741	9849	11188

¹ Repair Kit contains items 5, 6, 7, & 9. (and 5307 gasket for older models)

DIMENSIONS

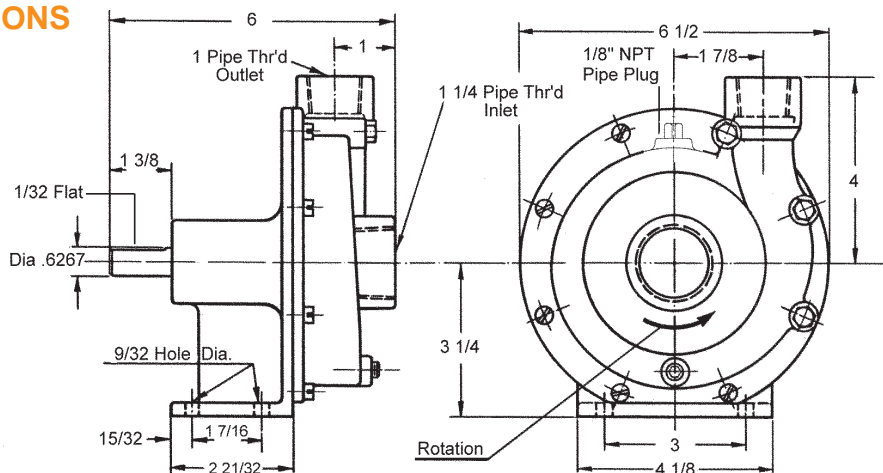

(continued from front)

LIQUIDS AND TEMPERATURES

Bronze pumps are suitable for most common liquids in the PH-range from 4 to 11.

The temperature limit for bronze pumps is 212°F, higher temperatures are possible with Viton® or Chemlon seals. If in doubt, consult with factory.

SHAFT SEAL OPTIONS

Mechanical Shaft Seals have Buna rubber components (212°F max) as standard. For temperatures up to 400°F a Viton® seal must be selected by adding code S10 to the pump number. To handle strong solvents and chemicals (compatible with bronze), a Chemlon seal (500°F max) must be specified by adding code S11 to the pump number.

In most instances, Viton® and Chemlon seals are not field interchangeable with the standard Buna seals. Call factory for details.

*Viton® is a registered trademark of DuPont Dow Elastomers. Viton(R) or equivalent FKM will be used.