

Mounting Instructions - M or N Type Universal Adapter Bracket

For Mounting Oberdorfer Bronze Rotary Gear Pump Models:

N999, N991, N992, N993 (No Relief)

N999R, N991R, N992R, N993R (With Relief)

To NEMA 48, S56, or 56 Frame Electric Motors

MOTORS

Model	HP @ 1725 RPM	Flow GPM	Pressure PSI
N999	1/4	to .46	to 150
N991	1/4	to 1.62	to 80
	1/3	to 1.35	to 125
	1/2	to 1.20	to 150
N992	1/3	to 3.08	to 60
	1/2	to 3.03	to 100
	3/4	to 2.50	to 150
N993	1/3	to 7.65	to 25
	1/2	to 6.60	to 55
	3/4	to 5.80	to 75

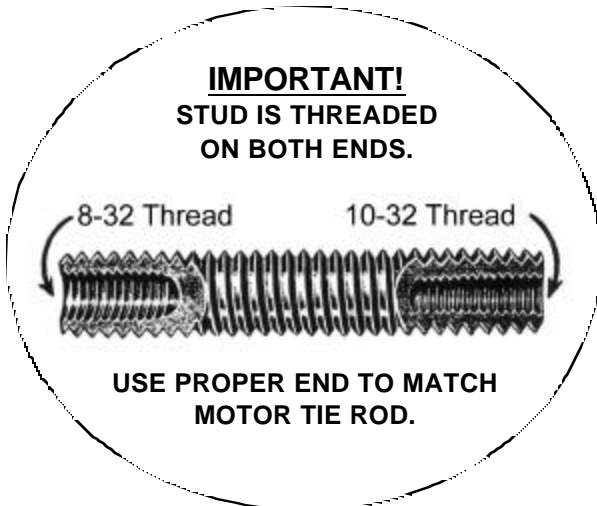
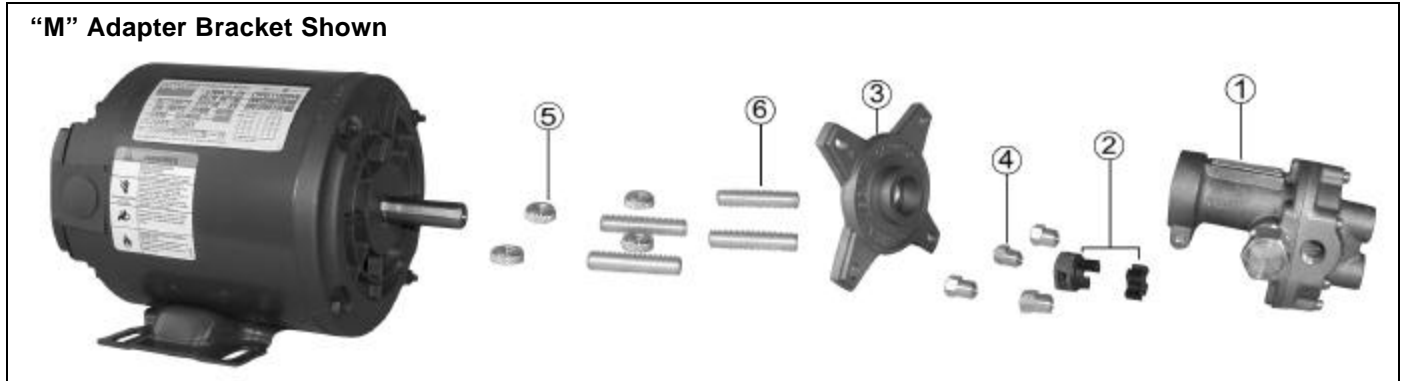

Contents of Assembly Package

Frame	1	2	3	4	5	6	Adapter Kit ¹
Motor	Gear Pump w/ Coupling Half	Coupling Half	Spider	Bracket	Acorn Nut	Adjust. Nut	
	1 Reqd	1 Reqd	1 Reqd	1 Reqd	4 Reqd	4 Reqd	4 Reqd
48	See	5604	7839	6656	6351	6350	6349
S56	Model Numbers	7643	7839	9420			
56	Above	7643	7839	6037			
							10562
							11722
							10816

¹ Adapter Kit contains items 2, 3, 4, 5, & 6.

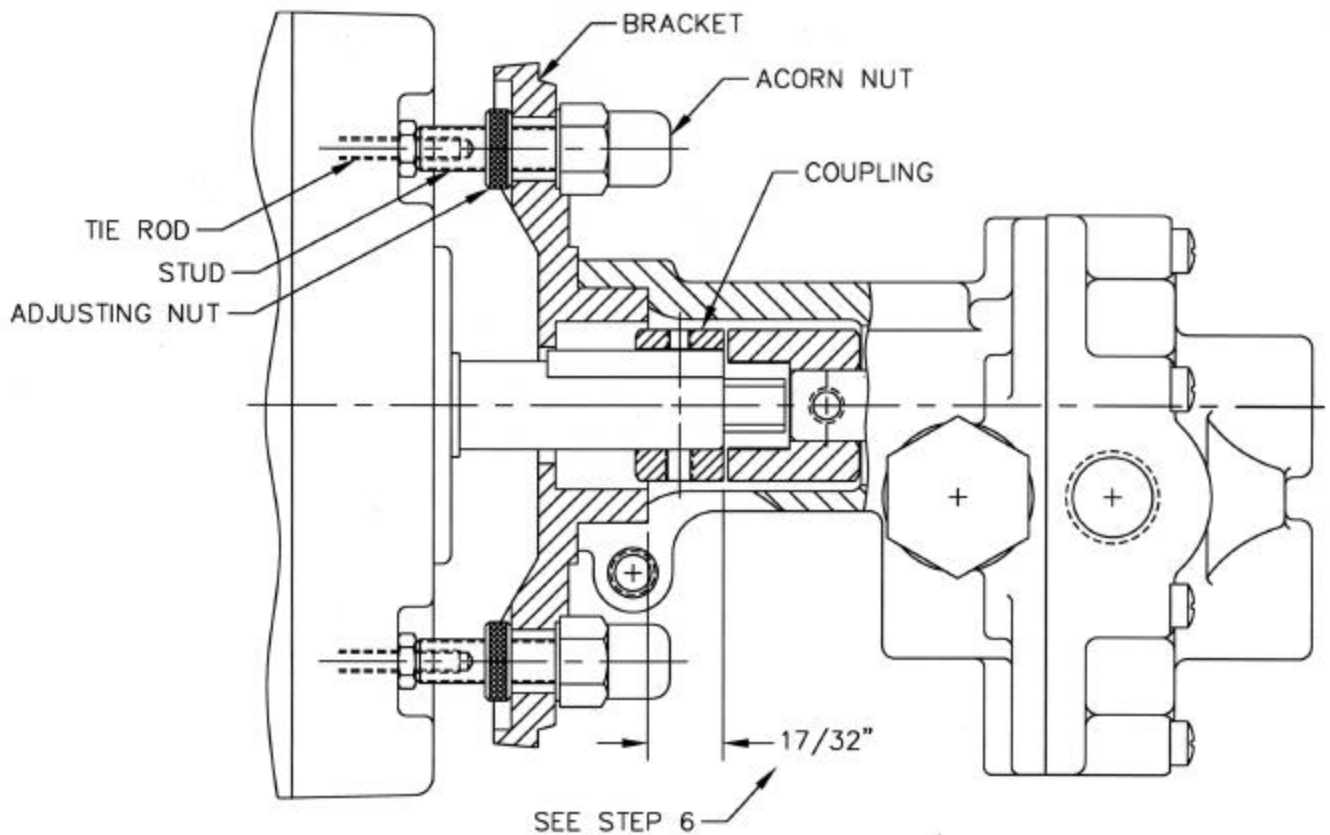

- 1) Remove the four (4) Tie Rod Nuts which hold the motor together. If necessary, reverse the Thru-Bolts for threaded end of bolts to be toward shaft end of motor.
- 2) Screw threaded Studs onto Tie Rods. Note: Some Tie Rods have 8-32 threads, some have 10-32 threads. Studs are threaded from both ends, select proper end.
- 3) Screw Adjusting Nuts onto Studs in preliminary position approximately 1/2" from the end of the Studs.
- 4) Slide Bracket over motor shaft onto the four (4) Studs so that it rests against the four (4) Adjusting Nuts.
- 5) Slip one Coupling Half onto motor shaft so that the shaft end is flush with the Hub Portion of the Coupling. Tighten Set Screw.
- 6) Adjust the four (4) Adjusting Nuts so that the distance between the end of the Motor Shaft and the front of the Bracket is 17/32". It is important that all four (4) Adjusting Nuts are about an equal distance away from the motor. This will insure squareness of the Bracket relative to the motor shaft.
- 7) Screw Acorn Nuts onto Studs. While tightening them with a wrench, rotate shaft by hand and make sure Shaft does not bind in Bracket.
- 8) Slide Gear Pump (with Rubber Spider and other Coupling Half on pump shaft) onto hub of Bracket. Check thru slot in bottom of Gear Pump for proper clearance between the Coupling Halves (approximately 1/16"). Tighten Clamp Screw to lock Gear Pump on Bracket.