

BRONZE ROTARY GEAR PUMPS

HIGH PRESSURE CARBONATOR MOTOR MOUNTED

1/4" NPT PORTS

N91060GRC with internal recirculation relief valve



N91060GEC with external return relief valve

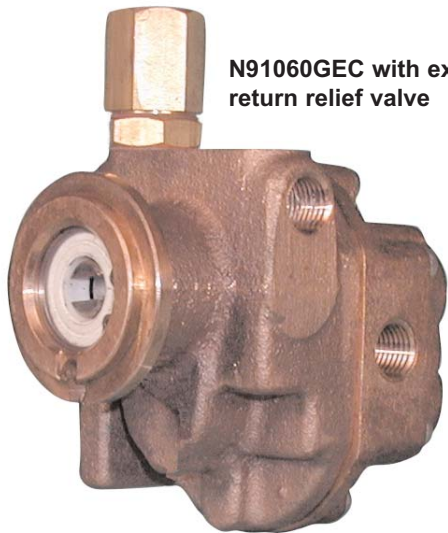

FEATURES

- Bronze Body, Stainless Steel Shaft
- Buna N Mechanical Seal (Viton optional)
- Self-lubricating Carbon Bearings
- Carbonator Motor Mount
- Bronze Spur Gears
- 200 PSI capability
- Superior to Vane Pumps

GENERAL DESCRIPTION

The carbonator motor mounting uses a circular clamp, similar to a hose clamp, as means of attaching the pump to a specially machined hub on the motor. This concept was first developed for the vending machine industry to pump carbonated beverages in soft drink dispensers. The main advantages are compactness and economy due to the elimination of the adapter casting. Carbonator motors are readily available from electric motor distributors.

PERFORMANCE

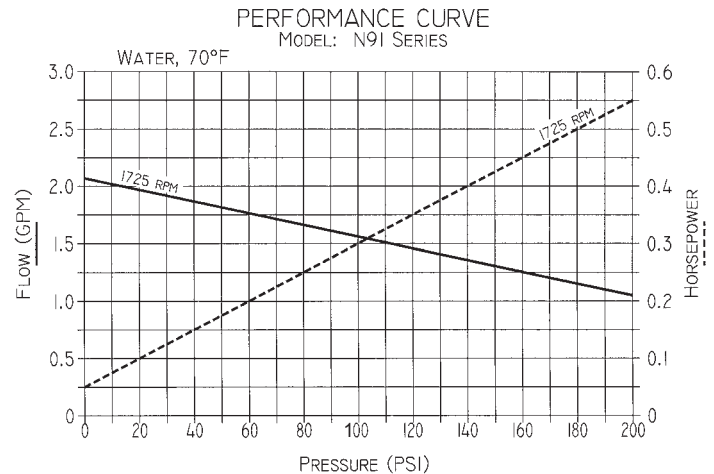

The rotary gear pump features an all bronze design and 303 stainless steel shafts with options of non-metallic gears and a variety of shaft seals. The built-in relief valve is available in multiple options; internal recirculation to suction side or external connection for return line to supply tank.

SUCTION LIFT

For a first start-up, the pump should be primed to avoid dry running. Gear pumps are self-priming, but a foot valve with strainer is recommended at the beginning of the suction line. This will keep the gear chamber primed to insure instant flow when the pump is started. maximum suction lift is 20 feet. The suction line should be as short as possible.

LIQUIDS AND TEMPERATURE

Bronze pumps are suitable for water, oil, and mild chemicals in the pH-range from 4-10. Viscous liquids may be handled with carbonator pumps up to a viscosity of 300 SSU. Higher viscosities require a pump speed lower than 1725 RPM, which is currently not available in carbonator motors.

Liquids containing abrasives, solids, powders or pigments are highly detrimental to pump life and must be avoided. The recommended liquid temperature range is from 32°F to 140°F. If more extreme temperature conditions exist, factory should be consulted. Allowing the liquid to freeze in the pump can cause damage.

ROTATION AND RELIEF VALVE

The relief valve is not intended to be a metering or flow control device. Its main purpose is to function as a discharge pressure relief when the spring tension is exceeded by the discharge pressure. Overheating can occur within 5-10 minutes if the discharge line is completely shut off for extended periods.

Unless otherwise specified, the pump motor unit is supplied by the factory for shaft rotation clockwise from shaft end. Reversing the motor rotation will reverse the "in" and "out" ports and also requires changing the relief valve location. The relief valve is always on the discharge side in this pump series. The factory pressure setting is 50 PSIG. To increase pressure, turn the relief valve adjusting screw in a clockwise direction. For relief settings between 100-200 PSI, specify high pressure spring (N91D)

To reverse single phase motors, find instructions on the inside of the junction box cover or on the name plate of the motor.

BRONZE ROTARY GEAR PUMPS

HIGH PRESSURE CARBONATOR MOTOR MOUNTED

EXPLODED VIEW AND PARTS LIST

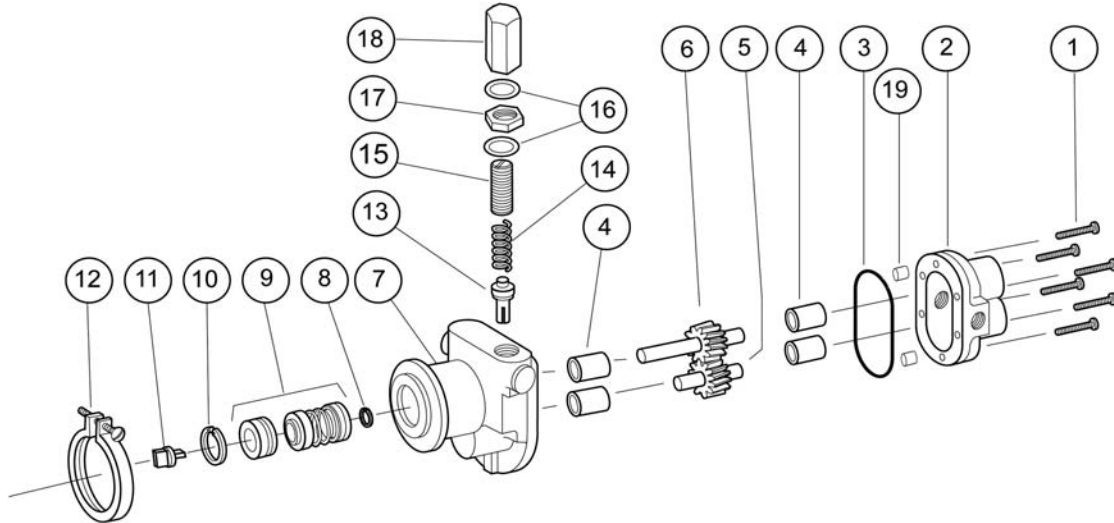

	1	2	3	4	5	6	7	8	9	10	11	12	13	14	15	16	17	18	19	
	Screw	Body	O-ring	Bearing	Idle Gear Assy	Drive Gear Assy	Cover	Snap Ring	Seal	Snap Ring	Coupler	Clamp	Poppet/Ball	Spring	Adjust. Screw	Fiber Washer	Lock Nut	Valve Nut	Dowel Pin	Repair Kit
Model	6 Req'd	1 Req'd	1 Req'd	4 Req'd	1 Req'd	1 Req'd	1 Req'd	1 Req'd	1 Req'd	1 Req'd	1 Req'd	1 Req'd	1 Req'd	1 Req'd	1 Req'd	2 Req'd	1 Req'd	1 Req'd	2 Req'd	
N91060GOC	7733	9300NB5N-C	9797-033	5024	32110	32914	9305NN4N-C	5373	32584	7639	9175	8840	---	---	---	---	---	---	8885	11969
N91060GKC	7733	9300NB5N-C	9797-033	5024	32110	32914	9305NN4L-C	5373	32584	7639	9175	8840	7640	5806	5766	6966	5774	5767	8885	11969
N91060GEC	7733	9300NB5N-C	9797-033	5024	32110	32914	9305NN4R-C	5373	32584	7639	9175	8840	7640	5806	5766	6966	5774	5767	8885	11969
N91060GRC	7733	9300NB5N-C	9797-033	5024	32110	32914	9305NN4B-C	5373	32584	7639	9175	8840	5809	5806	5766	6966	5774	5767	8885	11969
N91060GLC	7733	9300NB5N-C	9797-033	5024	32110	32914	9305NN4B-C	5373	32584	7639	9175	8840	5809	5806	5766	6966	5774	5767	8885	11969
N91D													7640H	6003						11969
N9105									32585											11968
N91K		9300NC5N-C																		

Model	Ports	Seal	Integrated Relief Valve					Rotation *
			Poppet or Ball	Spring	Internal or External* Return	Valve Position*		
N91060GOC	1/4	Buna	None					
N91060GKC	1/4	Buna	Poppet	Low Pressure	External / Left	Right	CW	
N91060GEC	1/4	Buna	Poppet	Low Pressure	External / Right	Left	CCW	
N91060GRC	1/4	Buna	Ball	Low Pressure	Internal	Right	CW	
N91060GLC	1/4	Buna	Ball	Low Pressure	Internal	Left	CCW	
N91D	1/4			High Pressure				
N9105	1/4	Viton						
N91K	3/8							

Notes: * facing pump shaft

Carbonator Style ODP Motors

Code	HP	Voltage	Frequency	Speed (RPM)	Thermal Overload	Part #
C33	1/4	115/230	60/50 HZ	1725 /1425	Auto	9630
C34	1/4	115	60 HZ	1725	Auto	9873
F02	1/3	115/230	60/50 HZ	1725 /1425	Auto	8876
F06	1/3	115	60 HZ	1725	Auto	9403
F12	1/3	230	60/50 HZ	1725 /1425	Auto	8520
J01	1/2	115	60 HZ	1725	Manual Reset	2240
J39	1/2	115	60 HZ	1725	Auto	3150
M40	3/4	115/230	60 HZ	1725	Auto	3151

DIMENSIONS

