

EXTENDED WEAR CLOSE COUPLED GEAR PUMP

MODEL N993R-66 (SHOWN WITH ADAPTER BRACKET)



FEATURES

- Compact design eases installation and use in limited space areas.
- Construction is bronze, PEEK and stainless steel wetted components.
- Bronze and PEEK gears for quiet operation and extended performance.
- Close tolerance design allows for consistent performance and suction lift, priming from 20 feet.
- Flow adjustment through integral bypass.

GENERAL DESCRIPTION

Pump housings are made of top quality bronze. The drive gear is bronze and the idle gear is PEEK. The shafts are 440C stainless steel hardened to a Rc 60, stress relieved and passivated. Bearings are made of high performance carbon-graphite material selected for wear resistance and extended service life.

Gear pumps are positive displacement pumps. Each shaft revolution displaces a definite amount of liquid relatively unaffected by the back pressure in the discharge line. Shaft speed and flow are directly proportional. Recommended pressure limits are 100 PSI for water and low viscosity fluids commonly used in the car wash industry. The maximum shaft speed is 1725 RPM.

DRIVE ARRANGEMENT

Close coupled gear pumps are mounted directly to the electric motor by means of a suitable adapter bracket. The pump drive is connected to the motor shaft by a flexible coupling. Adapterless motors are available.

LIQUIDS AND TEMPERATURE

These pumps are suitable for all liquids that are compatible with bronze. Most common liquids are water, oil, and mild chemicals in the pH range of 4 to 11. Viscous liquids require reduced shaft speeds of 1140 RPM or lower. (Consult factory.)

Liquids containing solids, abrasives, powders, or paint pigments

PERFORMANCE

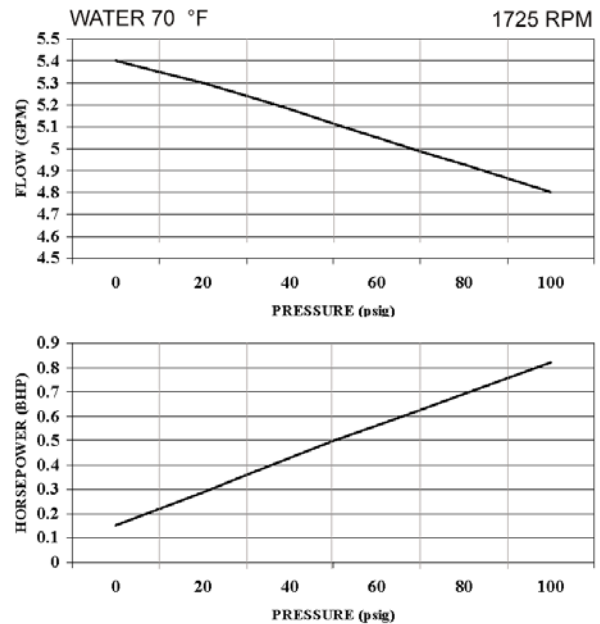

are definitely not recommended for gear pumps. If abrasives are unavoidable, use a very low shaft speed.

The recommended liquid temperature range is from 32^o F to 140^o F for best pump life. If more extreme temperature conditions exist, factory should be consulted. Freezing of water-filled pumps can cause damage and must be avoided. Some fluids at low temperatures can be viscous requiring a lower speed or extra power.

SUCTION LIFT

As a general rule, the suction lift should be kept at an absolute minimum by placing the pump as close to the liquid source as possible. A gear pump in new condition can lift 20 feet of water in the suction line. A foot valve (preferably with built-in strainer) is recommended at the beginning of the suction line. For a first start-up, the pump should be primed to avoid dry running. Minimum size of the suction pipe is the size of the pump inlet port. For longer suction lines (over 3 feet) or for viscous liquids, the pipe should be at least one size or two sizes larger than the pump inlet port.

SPECIFICATIONS

Differential Pressure:	100 PSI max.
Shaft Speed:	1725 RPM max.*
Suction Lift:	20" max.
Temperature:	32°F to 140° F
Fluid Viscosity:	33 - 50,000 SSU*

Notes:

* Maximum discharge pressure and shaft speed are reduced with higher fluid viscosities.

EXTENDED WEAR CLOSE COUPLED GEAR PUMP

EXPLODED VIEW

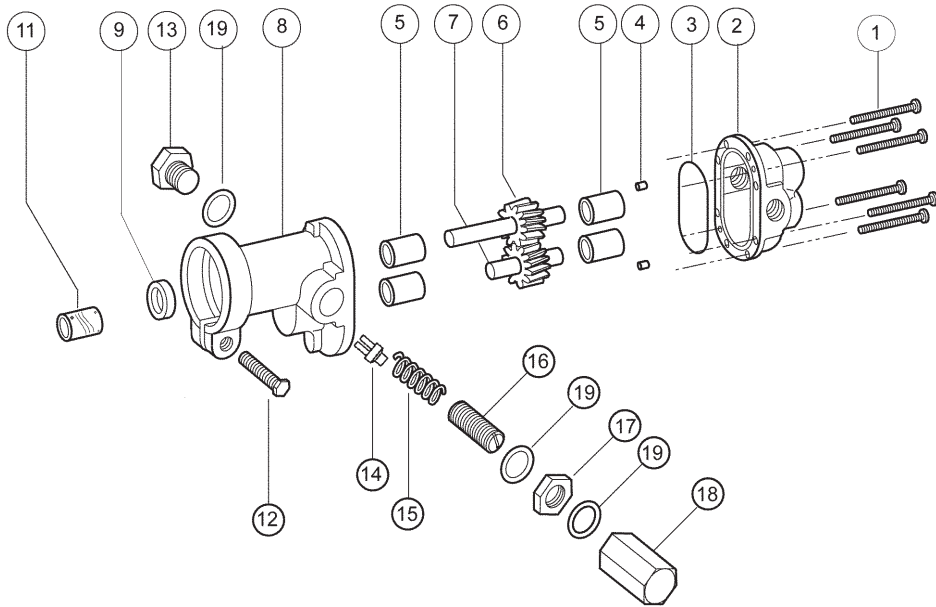

PARTS LIST

No.	Part Name	Req	N993 R-66 Part #
1	screw	6	9837 - I5
2	body assy.	1	9307N-06
3	o-ring	1	9797-038
4	dowel pin	2	8885
5	bearing	4	5024-01
6	drive gear assy.	1	33047
7	idle gear assy.	1	33048
8	cover (R)	1	9308N-06
9	lipseal, buna	1	5007
11	coupling	1	9363
12	screw	1	5595
13	nut plug	1	1838
14	poppet	1	6535
15	spring by-pass	1	6302
16	adj. screw	1	5237
17	nut lock	1	5240
18	nut by-pass	1	5239
19	fiber washer	3	6533

DRIVE GEAR ASSY 33047	
9359	drive gear
9361	drive shaft
9364	key
5373	retain rings (2)

IDLE GEAR ASSY 33048	
9360	idle gear
9362	idle shaft
9364	key
5373	retain rings (2)

DIMENSIONS

