

SEAL-LESS MAGNETIC DRIVE



A full range of accessories are available including:

- line mounted pressure relief valves
- pump mounting foot for use with footless motors

GENERAL DESCRIPTION

Chemsteel pumps are designed to handle highly corrosive liquids that must be pumped under pressure. Manufactured to extremely precise tolerance, the Chemsteel pump line prevents system contamination while maintaining the purity and integrity of the liquid being pumped. Its rugged, three-section, o-ring sealed thru-bolt construction provides ease of servicing and parts replacement.

Helical gearing offers noise reduction by as much as 10db.

Additionally, Chemsteel pumps offer bi-directional operation for applications requiring reversing flow.

LIFE CYCLE/COST OF OWNERSHIP

Pump design and materials selection, together provide the longest life available from a gear pump.

Key attributes include:

- Gear & bearing combinations of metallic and nonmetallic wear surfaces.
- Slotted bearings to lubricate shaft and gear surfaces.
- Hydraulic porting to balance axial thrust and to reduce wear.
- Ample port sizing to reduce the likelihood of cavitation when inlet pressure is marginal.
- Effective housing seals with elastic memory prevent leakage of corrosives.
- Recirculation heat port versatility.
- Containment can flush & drain connections.

PERFORMANCE

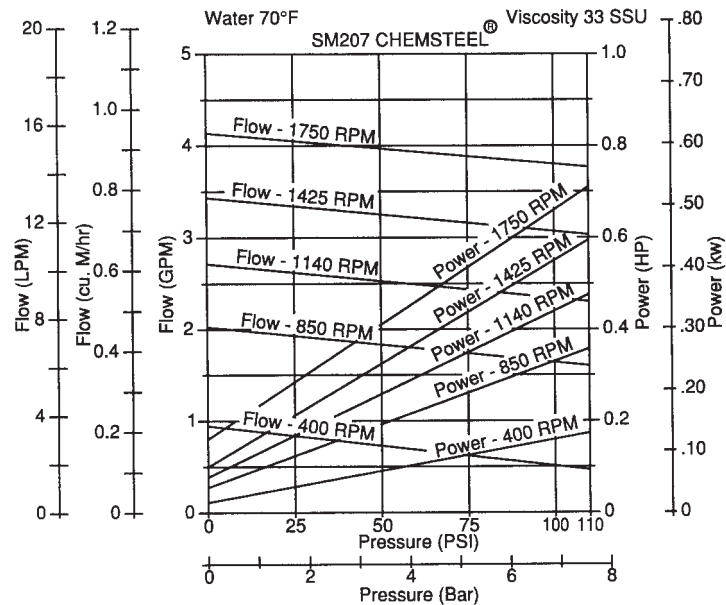

Notes: For continuous service:
Plastic / Plastic gear combinations are limited to 50 psi.
Metal / Plastic gear combinations are limited to 100 psi.

SPECIFIC SOLUTIONS

Gear/bearing design allows for "trimming" for optimizing the pump's maximum flow to reach minimum turndown or to match flow to a specific OEM's requirement.

Special materials combinations are available for specific liquids:

- Stainless or Alloy C housing construction.
- Gears available in metallic 316 stainless, W88 stainless and Alloy C. Also in Teflon®, Ryton® and PEEK®.
- Shafts are 316 stainless steel or Alloy C.
- Bearings available in Carbon, Teflon® and Rulon®

FIT

Connections are 1/2" female NPT or BSPT, pump hardware is metric and close couple adapters mount to both NEMA and IEC standard motor frame sizes for world wide acceptance. The port size is the same as competitive pumps.

MAINTENANCE

A three-part housing provides easy disassembly and service. Full size bearings match the gear diameter, and eliminate the need for separate wear plates. TFE encapsulating silicone o-ring pump housing seals provide elastic memory to assure an effective long lasting seal and thus avoiding the re-torquing required of pumps using pure TFE.

To order a CHEMkit[®], simply add a "K" to the end of the model number. A repair kit contains the following parts: bearings, gears, o-rings, shafts, keys, c clips, and retaining ring.

MODEL	SM207
Maximum Flow (gpm) @ 1750 RPM	4
Theoretical Displacement (cc/revolution)	11.2
Maximum Differential Pressure (psig)	110
Maximum System Pressure (psig)	300
Maximum Speed (RPM)	1800
Maximum Fluid Temperature	450° F
Minimum Fluid Temperature	-50° F
Max Viscosity @ 1750 RPM	100 SSU
NPSHR @ 1750 (feet)	4
Standard Port Size	1/2 inch FNPT
weight-less motor (lbs)	28

DIMENSIONS

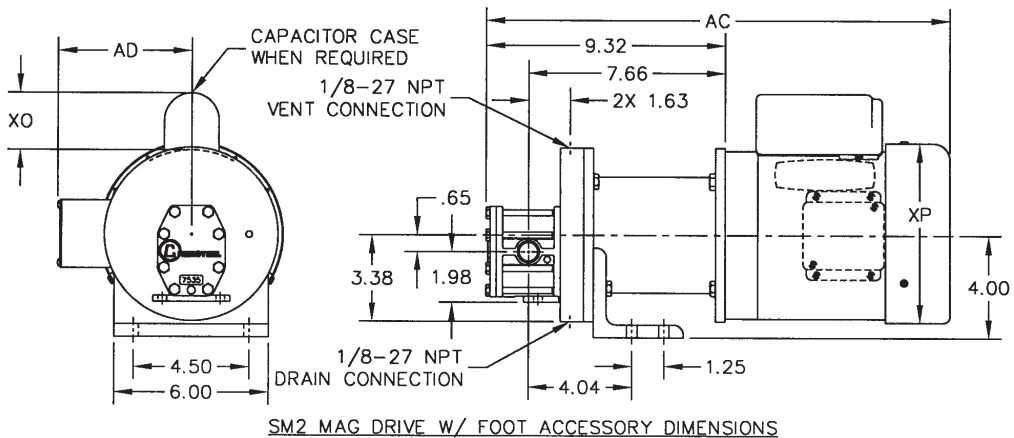
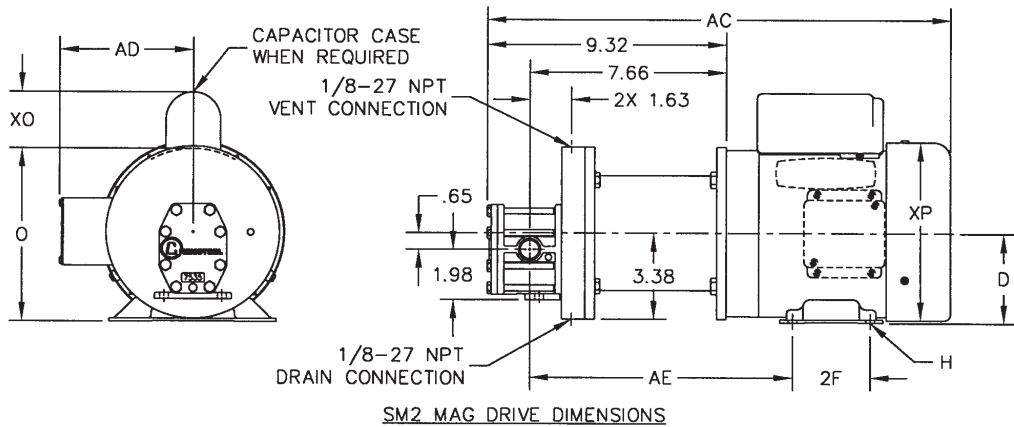

Mag Chemsteel Option Suffix	Power Kit Part No.	Motor Frame	AC*	D	2F	H	AE	AD	*O	*XO	*XP	
M1	MC2H56	56C	INCHES	18.07	3.50	3	.34 SLOT	10.22	5.31	6.81	2.25	7.16
			MILLIMETERS	459	88.9	76.2	8.6 SLOT	259.6	134.9	173	57.2	181.9
M2	MC2J45T	143TC/145TC	INCHES	21.45	3.5	4.00/5.00	0.34	10.54	5.31	6.81	2.25	7.16
			MILLIMETERS	544.8	88.9	101.6/127	8.6	267.7	134.9	173	57.2	181.9
M3	MC2F71E	IEC 71C, B14 FACE	INCHES	17.59	2.8	3.54	.28 SLOT	8.84	4.00	5.14	N/A	4.13
			MILLIMETERS	446.8	71	89.9	7.1 SLOT	224.5	101.6	130.6	N/A	104.9
M4	MC2T80E	IEC 80C, B14 FACE	INCHES	19.24	3.15	3.94	.39 SLOT	10.02	4.51	6	N/A	4.72
			MILLIMETERS	488.7	80	100.1	9.9 SLOT	254.5	114.6	152.4	N/A	119.9
M5	MC2U90E	IEC 90SC/90LC, B14 FACE	INCHES	20.34	3.54	3.94/4.92	.39 SLOT	10.26	5.12/4.25	6.81/6.53	N/A	5.51
			MILLIMETERS	516.6	90	100.1/125	9.9 SLOT	260.6	130/108	173/165.9	N/A	140

* Dimensions AC, O, XO and XP may vary depending on HP, Enclosure, Speed and Manufacturer

Teflon[®] is a registered trademark of DuPont, an equivalent fluoropolymer may be used.
 Ryton[®] is a registered trademark of Chevron Phillips Chemical, an equivalent polyphenylenesulfide may be used.
 PEEK[®] is a trademark of Victrex, an equivalent polyetheretherketone may be used.
 RULON[®] is a trademark of Saint-Gobain, an equivalent compounded PTFE based material may be used