

DUCTILE IRON CLOSE COUPLED ROTARY GEAR PUMPS

MODEL C990M2B1 - 1" NPT PORTS



FEATURES

- Ductile Iron construction with hardened steel shafts
- Fatigue Proof® steel helical gears for quiet operation
- Mechanical seal
- Self lubricating carbon radial and thrust bearings
- O-ring seal for maximum leak protection
- Durable temperature-resistant paint finish
- Easy field assembly to C-face motors
- Compact dimensions

GENERAL DESCRIPTION

Tailored specifically for wear resistance and long life in pressurized heat transfer oil circulation service for plastic injection molding and other industries. They are industrial units designed to handle fluctuating temperature cycles pumping Therminol®, Dowtherm®, Paratherm® and others at elevated temperatures to 450 °F, at pressures up to 100 psi, and at shaft speeds to 1750 RPM. Shafts are hardened steel. Gears are high-strength durable Fatigue Proof® steel. Rugged ductile iron housings. High grade carbon-graphite bushing style bearings and thrust plates are used. The shaft seal is a bellows style mechanical seal with Viton® elastomer bellows and o-ring and with carbon and ceramic wear faces. No stuffing box cooling necessary. Contact Factory for 550 °F option.

DRIVE ARRANGEMENT

These close-coupled pumps mount directly to a full range of NEMA and IEC C-face motors by means of a suitable adapter bracket. The pump drive shaft is connected to the motor shaft by a flexible coupling. Complete pump and motor units are available.

SUCTION LIFT

Whenever possible, place the pump at an elevation below the liquid source. However since these positive displacement external gear pumps will generate 23" HG lift, this is not a requirement. As a general

PERFORMANCE

PERFORMANCE
Water 70° F

1725 RPM					Pump, Adapter & TEFC Motor No.	
PSI	GPM	HP Req'd	HP Motor	Motor Frame	Single Phase	Three Phase
0	22.5	0.90	1	56C	C990M2B1H-N47	C990M2B1H-N97
20	22.0	1.19	1 1/2	56C	C990M2B1H-T47	
				145TC		C990M2B1J-T52
40	21.4	1.53	1 1/2	56C	C990M2B1H-T47	
				145TC		C990M2B1J-T52
60	20.8	1.92	2	145TC	C990M2B1J-W47	C990M2B1J-W97
80	20.3	2.25	3	182TC		C990M2B1K-Y97
				184TC	C990M2B1K-Y44	
100	20.0	2.70	3	182TC		C990M2B1K-Y97
				184TC	C990M2B1K-Y44	

1150 RPM					Pump, Adapter & TEFC Motor No.	
PSI	GPM	HP Req'd	HP Motor	Motor Frame	Single Phase	Three Phase
0	14.8	0.58	3/4	56C	C990M2B1H-M48	C990M2B1H-M98
20	14.4	.77	3/4	56C	C990M2B1H-M48	C990M2B1H-M98
40	14.0	1.10	1	145TC	C990M2B1J-N48	C990M2B1J-N98
				145TC		C990M2B1J-T98
60	13.5	1.40	1 1/2	184TC	C990M2B1K-T48	
				184TC	C990M2B1K-W48	C990M2B1K-W71
80	13.2	1.80	2	184TC	C990M2B1K-W48	C990M2B1K-W71
100	12.9	2.10	2	184TC	C990M2B1K-W48	C990M2B1K-W71

ODP motors available

rule, place the pump as close to the liquid source as possible. For a first start-up, the pump should be primed to avoid dry running. Minimum size of the suction pipe is the size of the pump inlet port. For longer suction lines (over 3 feet), the pipe size should be at least one size or two sizes larger than the pump inlet port.

ROTATION AND RELIEF VALVE

These pumps are bidirectional. The standard pump motor unit is set up for normal rotation (clockwise when viewing the pump from the shaft end). Reversing the motor rotation will reverse the "in" and "out" ports and also requires changing the relief valve location.

C990RM2B1 is equipped with an integrated relief valve set up for internal bypassing. The relief valve must always be located on the discharge side of the pump. This relief valve is not intended to be a metering or flow control device. Its purpose is to function as a discharge pressure relief to guard against intermittent down stream system restrictions. Overheating can occur within 5 to 10 minutes if the discharge line is completely shut off. The relief valve is located on the discharge side of the pump. The pressure relief setting is not set at the factory. To increase pressure, turn the relief valve adjusting screw in a clockwise direction.

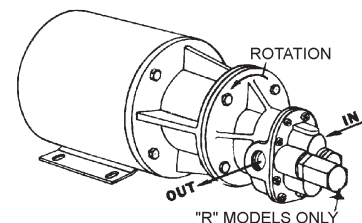

MODEL
C990M2B1
C990RM2B1

DUCTILE IRON CLOSE COUPLED ROTARY GEAR PUMPS

DIMENSIONS & PARTS LIST

DIMENSIONS AND PARTS LIST C990M2B1

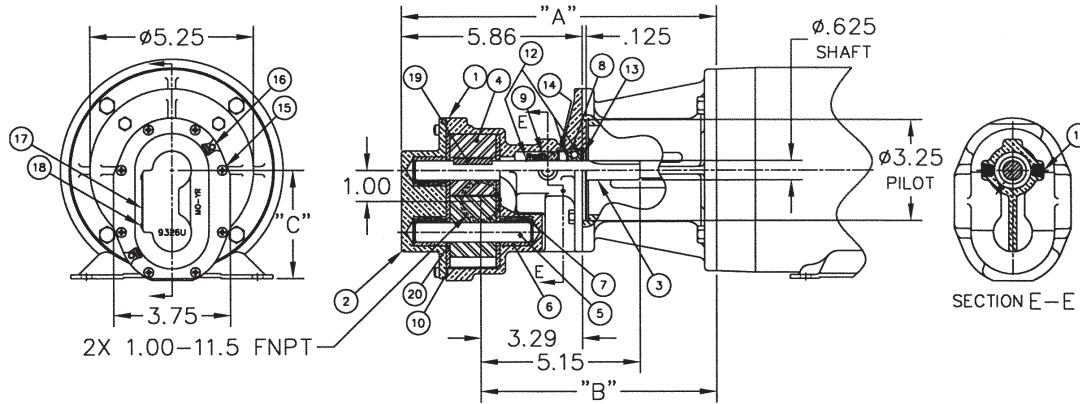

DIMENSIONS AND PARTS LIST C990RM2B1

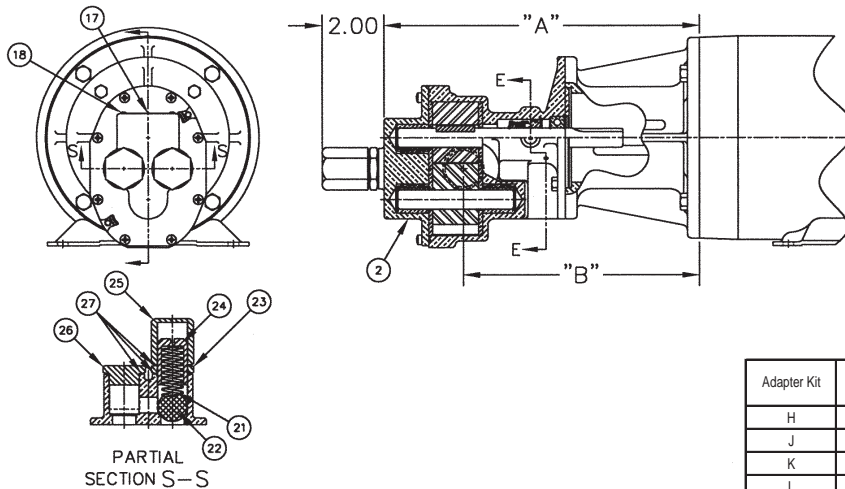

Adapter Kit	Part Number	Description
H	11299C	56C Frame
J	11300C	143TC/145TC
K	11301	182TC/184TC
L	11302	213TC/215TC
G	11380	IEC 71
T	11386	IEC 80
U	11875C	IEC 90S/90L
V	11876C	IEC 100L/112M

Adapter Kit	Adapter Kit Part Number	Motor Frame	Dim. 'A'	Dim. 'B'	Dim. 'C'
H	11299C	56C	10.17	7.60	3.50
J	11300C	143TC/145TC	10.17	7.60	3.50
K	11301	182TC/184TC	10.99	8.42	4.50
L	11302	213TC/215TC	10.99	8.42	5.25

	1	2	3	4	5	6	7	8	9	10	11	12	13	14
	Body	Cover	Drive Shaft	Drive Gear	Idle Gear Assy	Carbon Bearing	Bearing Pin	Ball Bearing	Mech. Seal Assy	O-Ring	Pipe Plug	Ret. Ring	Ret. Ring	Ret. Ring
Pump No.	Qty. 1	Qty. 1	Qty. 1	Qty. 1	Qty. 1	Qty. 3	Qty. 3	Qty. 1	Qty. 1	Qty. 1	Qty. 2	Qty. 3	Qty. 1	Qty. 1
C990M2B1	9329UF4N-01	9326UN5N	2949	2394	33126	2688	2687	2461	33109	9797-045	2052	5382	5464	5374
C990RM2B1	9329UF4N-01	9327UN5B	2949	2394	33126	2688	2687	2461	33109	9797-045	2052	5382	5464	5374
	15	16	17	18	19	20	21	22	23	24	25	26	27	
	Screw	Dowel Pin	Tag	Stick Screw	Key	Thrust Washer	Spring	Ball	Locknut	Adj. Screw	Bypass Nut	Plug Nut	Fiber Washer	
Pump No.	Qty. 8	Qty. 2	Qty. 1	Qty. 2	Qty. 1	Qty. 4	Qty. 1	Qty. 1	Qty. 1	Qty. 1	Qty. 1	Qty. 1	Qty. 3	
C990M2B1	5385	8885	9344	9345	6845	2899	N/A	N/A	N/A	N/A	N/A	N/A	N/A	
C990RM2B1	5385	8885	9344	9345	6845	2899	5277	6217	1642	5275	5276	5278	6965	

Repair Kit 12293 includes items 3, 4, 5, 6, 7, 8, 9, 10, 12, 13, 14, 19 & 20

*Viton® or equivalent FKM will be used. Viton® is a trademark of DuPont Dow Elastomers.
Dowtherm® is a trademark of the Dow Chemical Corporation.

Paratherm® is a trademark of the Paratherm Corporation
Thermino® is a trademark of Solutia Inc.
Fatigue Proof® is a trademark of Niagara LaSalle Corporation