

BRONZE CLOSE COUPLED ROTARY GEAR PUMPS

MODEL N994 - 1/2" NPT PORTS

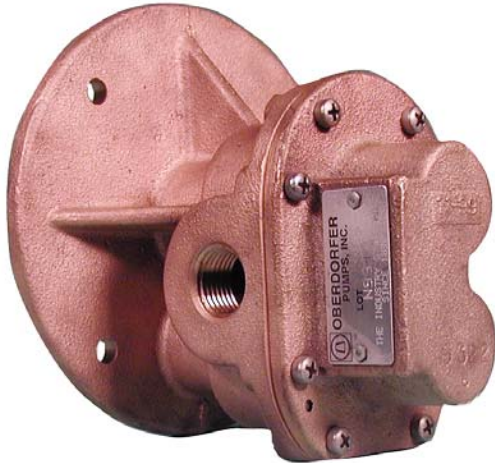

FEATURES

- Bronze Construction with Stainless Steel Shafts
- Helical gears for quiet operation
- Easy Field Assembly to Motors
- Self-Lubricating Carbon Bearings
- O-ring seal for maximum leak protection
- For clutch driven version, see N994-38

GENERAL DESCRIPTION

Pump housings and gears are made of top quality bronze, shafts are stainless steel 303. Bearings are made of high performance carbon-graphite material selected for wear resistance and long service life.

Gear pumps are positive displacement pumps. Each shaft revolution displaces a definite amount of liquid relatively unaffected by the back pressure in the discharge line. Shaft speed and flow are directly proportional.

DRIVE ARRANGEMENT

Close coupled pumps are mounted directly to the electric motor by means of a suitable adapter bracket. The pump drive shaft is connected to the motor shaft by a flexible coupling.

LIQUIDS AND TEMPERATURE

These pumps are suitable for all liquids that are compatible with bronze. Most common liquids are water, oil, and mild chemicals in the pH-range of 4 to 11. Viscous liquids require reduced shaft speeds of 1150 RPM or lower. Consult factory.

Liquids containing solids, abrasives, powders or paint pigments are definitely not recommended for gear pumps. If abrasives are unavoidable, use a very low shaft speed. The recommended liquid temperature range is 32°F to 140°F for longest pump life. If more extreme temperature conditions exist, our factory should be consulted. Freezing of water-filled pumps can cause damage and must be avoided. Oils at low temperatures are very viscous requiring a lower speed or extra power.

PERFORMANCE

Water 70° F

1725 R.P.M.					Pump & Motor No.	
PSI	GPM	HP Req.	HP Motor	Motor Frame	Single Phase	Three Phase
0	10.5	0.50	1/2	56C	N994HJ45	N994HJ95
20	10.3	0.75	3/4	56C	N994HM26	N994HM95
40	10.1	0.9	1	56C	N994HN26	N994HN95
60	9.9	1.2	1 1/2	145TC	N994JT45	N994JT95
80	9.6	1.5	1 1/2	145TC	N994JT45	N994JT95
100	9.4	1.75	2	145TC	N994JW45	N994JW95
125*	9.2	2	2	145TC	N994JW45	N994JW95
150*	9	2.32	3	182TC	N994KY45	N994KY95

1150 R.P.M.					Pump & Motor No.	
PSI	GPM	HP Req.	HP Motor	Motor Frame	Single Phase	Three Phase
0	6.9	0.24	1/2	56C	N994HJ46	N994HJ96
20	6.6	0.29	1/2	56C	N994HJ46	N994HJ96
40	6.4	0.43	1/2	56C	N994HJ46	N994HJ96
60	6.1	0.58	3/4	56C	N994HM46	N994HM96
80	5.9	0.72	3/4	56C	N994HM46	N994HM96
100	5.6	0.93	1	145TC	N994JN46	N994JN96
125*	5.4	1.25	1 1/2	145TC	N994JT46	N994JT96
150*	5.2	1.63	2	184TC	N994KW46	N994KW96

*For pressures over 100 psi, the above selections are suitable for pumping fluids with lubricity (e.g. oils, polymers). Service life will decrease for fluids without lubricity (e.g. water, solvents).

SUCTION LIFT

As a general rule, the suction lift should be kept at an absolute minimum by placing the pump as close to the liquid source as possible. A gear pump in new condition can lift 20 feet of water in the suction line. A foot valve (preferably with built-in strainer) is recommended at the beginning of the suction line. For a first start-up, the pump should be primed to avoid dry running. Minimum size of the suction pipe is the size of the pump inlet port. For longer suction lines (over 3 feet), or for viscous liquids, the pipe size should be at least one size or two sizes larger than the pump inlet port.

ROTATION AND RELIEF VALVE

The relief valve is not intended to be a metering or flow control device. Its main purpose is to function as a discharge pressure relief when the spring tension is exceeded by the discharge pressure. Overheating can occur within 5-10 minutes if the discharge line is completely shut off for extended periods.

Unless otherwise specified, the pump motor unit is supplied by the factory for shaft rotation clockwise from shaft end. Reversing the motor rotation will reverse the "in" and "out" ports and also requires changing the relief valve location. The relief valve is always on the discharge side in this pump series. The factory pressure setting is 50 PSIG. To increase pressure, turn the relief valve adjusting screw in a clockwise direction.

To reverse single phase motors, find instructions on the inside of the junction box cover or on the name plate of the motor.

Three phase motors are not wired for any particular rotation. They can be reversed by interchanging any two (2) wires of the three (3) wire leads.

BRONZE CLOSE COUPLED ROTARY GEAR PUMPS

EXPLODED VIEW & PARTS LIST

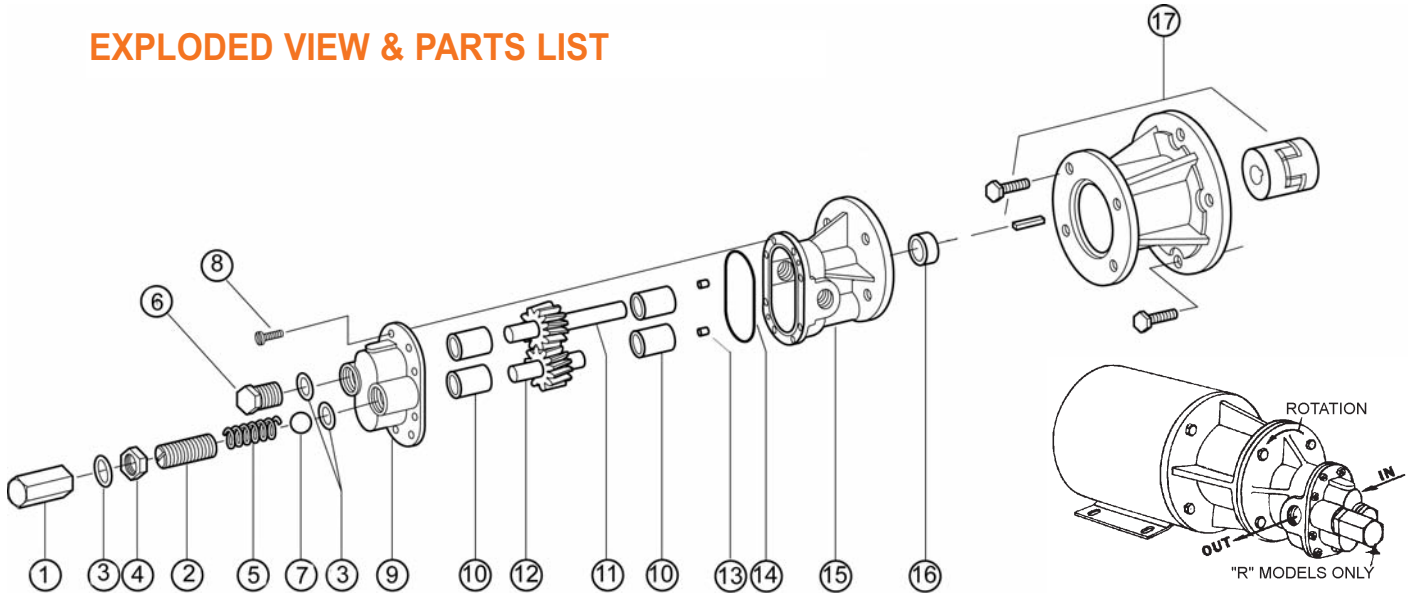

Pump No.	1	2	3	4	5	6	7	8	9	10 ¹	11 ¹	12 ¹	13	14 ¹	15	16 ^{1,2}	17
	Bypass Nut	Adj. Screw	Fiber Washer	Locknut	Spring	Plugnut	Ball	Screw	Cover	Bearing	Drive Gear Assy.	Idle Gear Assy.	Dowel Pin	O-Ring	Body	Lipseal	Adapter Kits
	1 Req'd	1 Req'd	3 Req'd	1 Req'd	1 Req'd	1 Req'd	1 Req'd	8 Req'd	1 Req'd	4 Req'd	1 Req'd	1 Req'd	2 Req'd	1 Req'd	1 Req'd	1 Req'd	
N994	—	—	—	—	—	—	—	5385	9322NN5N	5091	33011	33008	8885	9797-041	9320ND2N	5463	See
N994R	5204	5200	6964	5209	5207	5205	5206	5385	9323NN5B	5091	33011	33008	8885	9797-041	9320ND2N	5463	Below

¹ Repair kits contain items 10, 11, 12, 14 & 16. Repair kit for N994(R) is 11333.

² Part # 5463 is standard Buna N, part #9997 is Viton(R)*-Teflon(R)*.

Adapter Kits

Adapter Kit	Part Number	Description
H	11299	56C Frame
J	11300	143TC/145TC
K	11301	182TC/184TC
L	11302	213TC/215TC

Variations

Pump Model	16 ^{1,2}	Description	Repair Kit
	Lipseal		
N994S15	9997	Viton(R)*-Teflon(R)*	12100
N994RS15	9997	Viton(R)*-Teflon(R)*	12100

Motor/Adapter Kit Dimensions (see below)

Model	Motor Frame	"A"	"B"	"C"
N994(R)H	56C	8.63	6.50	3.50
N994(R)J	143TC/145TC 182C/184C	8.63	6.50	3.50
N994(R)K	182TC/184TC 213C/215C	9.45	7.31	4.50
N994(R)L	213TC/215TC	9.45	7.31	5.25

DIMENSIONS

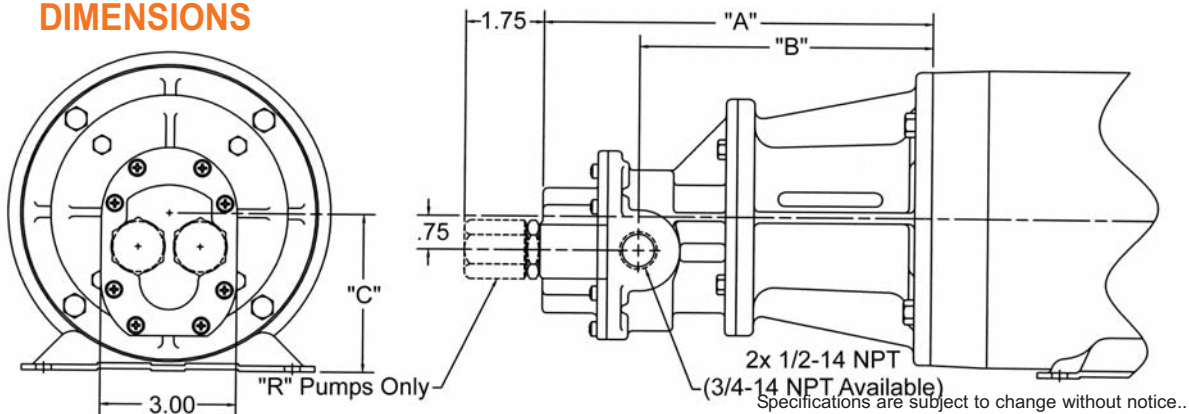

*Viton(R) or equivalent FKM will be used. Viton(R) is a trademark of DuPont Dow Elastomers.
Teflon(R) or equivalent PTFE will be used. Teflon(R) is a registered trademark of DuPont.